



**MITSUBISHI ELECTRIC AUTOMATION (THAILAND) CO., LTD.**

Bang-Chan Industrial Estate No. 111 Moo 4, Serithai Rd., T.Kannayao, A.Kannayao, BKK 10230 Thailand  
 Tel: (66) 2517-1326, (66) 2919-9873 Fax: (66) 2517-1328 URL: www.meath-co.com E-mail: support@meath.co.th

**บริษัท มิทซูบิชิ อิเล็กทริก ออโตเมชัน (ประเทศไทย) จำกัด**

นิคมอุตสาหกรรมบางชัน เลขที่ 111 หมู่ 4 ถนนเสรีไทย แขวงคันนายาว เขตคันนายาว กทม. 10230

โทรศัพท์: (66) 2517-1326, (66) 2919-9873 โทรสาร: (66) 2517-1328 URL: www.meath-co.com E-mail: support@meath.co.th

**MOTOR SPECIFICATION SHEET**

MODEL : SF-QR 7.5HP 4P (LT)

USED FOR : STANDARD

DESCRIPTION	DETAIL			
PHASE	3			
MODEL NAME	SF-QR			
RATED OUTPUT, HP (kW)	7.5 (5.5)			
POLE	4			
CODE	MEATH CODE : 1M002F-400550QRGD0			
OUTLINE DRAWING NO.	ONM24O161-C			
RATED VOLTAGE (V)	220	380	415	
RATED FREQUENCY (Hz)	50	50	50	
RATED CURRENT (A)	20.2	11.7	11.6	
RATED SPEED (min <sup>-1</sup> )	1450	1450	1460	
RATED EFFICIENCY (%)	84.7	84.7	84.7	
EFFICIENCY CLASS	IE1			
THERMAL CLASS	155(F)			
RATING	S1 (CONTINUOUS)			
ENCLOSURE CONSTRUCTION	TOTALLY ENCLOSED FAN COOLED			
DEGREES OF PROTECTION	IP55			
METHOD OF COOLING	IC411			
FRAME NO.	132S			
WEIGHT (kg)	46.8			
STANDARD	IEC 60034-1, IEC 60034-30-1			
INSTALLATION	FOOT MOUNTED			
ROTATION	CCW (VIEWED FROM SHAFT END)			
BEARING	LOAD SIDE : 6308ZZ			
	OPPOSITE SIDE : 6207ZZ			
BEARING GREASE	UREA GREASE			
NOISE (dB.A)	74			
VIBRATION	V10			
CIRCUMSTANCE CONDITION	AMBIENT TEMPERATURE : -20 ~ +40°C			
	AMBIENT HUMIDITY : 95%RH OR LESS			
	ABOVE SEA LEVEL : 1000m OR LESS			
	ENVIRONMENT : NO BURSTING/EROSIVE GAS OR VAPOR			
COLOR	MUNSELL N1.5 (BLACK)			
TERMINAL BOX	NO. OF LEAD WIRES : 6			
	SOURCE CONNECTION : TERMINAL BLOCK			
SHAFT SWING	≤0.03mm			
MATERIAL	FRAME : STEEL PLATE			
	BRACKET : ALUMINIUM			
	SHAFT : CARBON STEEL			
	STATOR CORE : ELECTRICAL STEEL			
	WIRE : ENAMELLED COPPER MAGNET WIRE			
	ROTOR CORE : ELECTRICAL STEEL			
	CONDUCTOR : ALUMINIUM			
	TERMINAL BOX : STEEL PLATE			
	PAINTING : POLYURETHANE RESIN			
PRODUCTION COUNTRY	THAILAND			

Specifications subject to change without notice.

<b>SPECIFICATION SHEET NO.</b>				
SS-M-2768-A				

# MODEL SF-QR THREE PHASE INDUCTION MOTOR OUTLINE DRAWING

TOTALLY ENCLOSED FAN COOLED TYPE  
 DEGREES OF PROTECTION IP55  
 DUST & WATER JET PROOF

CUSTOMER \_\_\_\_\_  
 USER \_\_\_\_\_  
 FOR \_\_\_\_\_  
 CUSTOMER'S ORDER NO. \_\_\_\_\_  
 QUANTITY \_\_\_\_\_  
 MFG. ORDER NO. \_\_\_\_\_

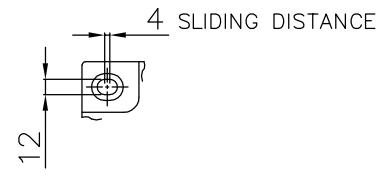
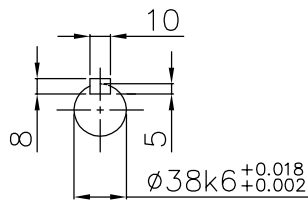
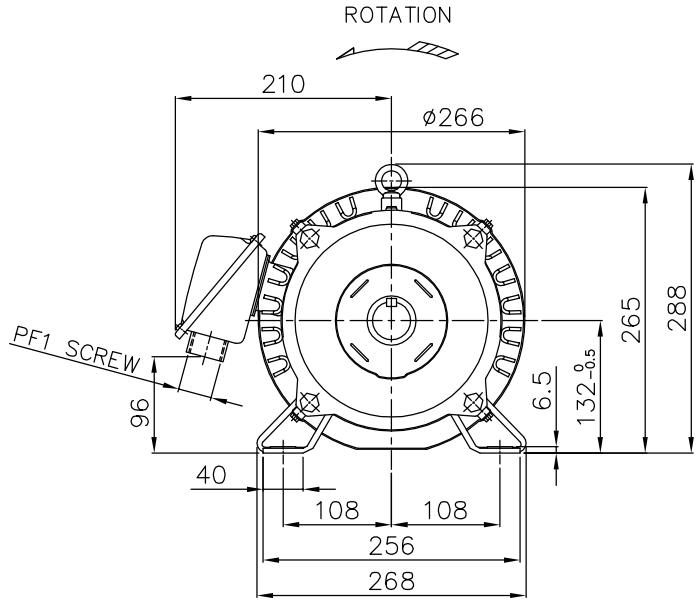
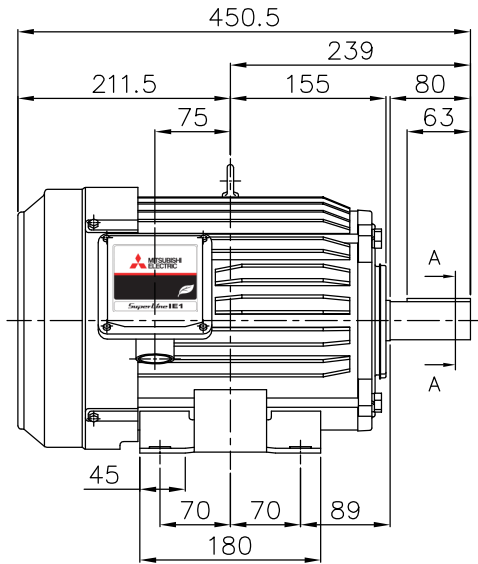

SECTION A-A

FRAME FOOT AS VIEWED FROM BELOW

YOUR ORDER	FRAME SIZE	RATING	TH. CLASS	AMB. TEMP.	BEARINGS		COLOR	DIRECTION OF ROTATION (VIEWED FROM SHAFT END)	NO. OF LEAD WIRES	REMARKS
					LOAD SIDE	OPP. SIDE				
	132S	S1 (CONT.)	155(F)	40°C	6308ZZ	6207ZZ	BLACK (MUNSELL N1.5)	CCW	6	

YOUR ORDER	OUTPUT		POLES	VOLTS	HERTZ	AMP.	RPM	IE CODE-RATED EFF.	REMARKS
	HP	KW							
	7.5	5.5	2	220/380/415	50	19.7/11.4/11.3	2885/2885/2910	IE1 84.7%/84.7%/84.7%	LT
	10	7.5	2	220/380/415	50	25.5/14.7/14.0	2890/2890/2910	IE1 86.0%/86.0%/86.0%	LT
	7.5	5.5	4	220/380/415	50	20.2/11.7/11.6	1450/1450/1460	IE1 84.7%/84.7%/84.7%	LT
	5	3.7	6	220/380/415	50	14.5/8.4/8.3	950/950/960	IE1 81.8%/81.8%/81.5%	LT
	7.5	5.5	2	380/415	50	11.4/11.2	2900/2910	IE1 84.7%/84.7%	HT
	10	7.5	2	380/415	50	14.8/14.2	2900/2920	IE1 86.0%/86.0%	HT
	7.5	5.5	4	380/415	50	11.7/11.7	1450/1460	IE1 85.8%/85.6%	HT
	5	3.7	6	380/415	50	8.52/8.50	950/960	IE1 81.8%/81.5%	HT

MITSUBISHI ELECTRIC AUTOMATION (THAILAND) CO., LTD.

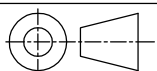

DIMENSION IN mm.  
 SCALE : NTS

OUTLINE DRAWING NO.

0 N M 2 4 0 1 6 1

REV.

C